

Exova Warringtonfire
Chiltem House
Stocking Lane
Hughenden Valley
High Wycombe
Buckinghamshire
HP14 4ND

T: +44 (0) 1494 569 800
F: +44 (0) 1494 564 895
E: globalfire@exova.com
W: www.exova.com



Testing, calibrating, advising.

Title:

Global Fire Resistance
Assessment
Vistamatic VS2 Vision Panel
Fire Resisting Timber Doorset
Assemblies
30 Minute Fire Resistance

Report No:

Chilt/A12242 Revision A

WF Contract:

WF404612

Valid From: 11th October 2018

Valid Until: 11th October 2023

Prepared for:

Vistamatic Ltd

51 – 55 Fowler Road
Hainault Industrial Estate
Hainault
Essex
IG6 3XE

Exova Warringtonfire – the new name for BM TRADA

On December 1st 2015, Chiltern International Fire Limited (trading as BM TRADA) commenced trading under the name Exova Warringtonfire.

To coincide with this change, our Technical Reports, Test Reports, Product Assessments, company stationery and marketing collateral have been updated to reflect the Exova Warringtonfire branding.

The validity of all documents previously issued by Chiltern International Fire Limited including certificates, test reports and product assessments is unaffected by this change. A letter to this effect is available upon request by e-mailing globalfire@exova.com

About Exova Warringtonfire

Exova Warringtonfire is part of the Exova Group one of the world's leading laboratory-based testing groups, trusted by organisations to test and advise on the safety, quality and performance of their products and operations. Headquartered in Edinburgh, UK, Exova operates 143 laboratories and offices in 32 countries and employs around 4,500 people throughout Europe, the Americas, the Middle East and Asia/Asia Pacific. With over 90 years' experience, Exova specialises in testing across a number of key sectors from health sciences to aerospace, transportation, oil and gas, fire and construction. Be assured that whilst the name will change, your service provision and primary contacts have not. What will be available to you is a wider team of testing experts and an extended range of testing capabilities including structural steelwork testing, ventilation duct and damper testing, ASTM testing, water mist system testing and smoke toxicity testing and covering additionally both the rail and marine sectors.

If you have any questions, please do not hesitate to contact a member of the team and we will do our best to answer them. We appreciate your business to date and we look forward to working with you in the future.

Kind regards

Exova Warringtonfire

T: +44 (0) 1494 569 800

E:globalfire@exova.com

Contents

	Page No
1 Introduction	4
2 Description of Vistamatic VS2	5
2.1 General.....	5
2.2 Timber Beads	6
2.3 Steel Beads	7
3 Scope of Application for Vistamatic VS2	8
3.1 Proprietary fire resisting doors	8
3.2 Non-proprietary timber based fire resisting doors.....	8
3.3 Assessed Glass	9
4 Data Sheets	10
4.1 Falcon Panel Products – Strebord 44	10
4.2 Halspan Ltd – Prima 30	10
4.3 Pacific Rim Wood Ltd – Flamebreak 30	10
4.4 Blankfort Inc – Blankfort 30	11
4.5 Egger (UK) Ltd – Eurospan 30.....	11
5 Side Panels and Fanlights.....	11
6 Additional Installation Requirements	13
7 Conclusion	13
8 Declaration by the Applicant.....	14
9 Limitations.....	15
10 Validity	15
Appendix A Performance Data.....	16
Appendix B Revisions	17

1 Introduction

This document constitutes a scope of application report relating to the Vistamatic VS2 vision panel system for 30 minute fire resisting doorset installations, on behalf of Vistamatic Ltd. The report summarises the scope of application of the Vistamatic VS2 vision panel when used to glaze timber based fire resisting doorsets, glazed sidescreens and fanlights, and will be based on the associated test and assessment data.

The report uses established extrapolation and interpretation techniques in order to extend the scope of application by determining the limits for the vision panel, based on the tested constructions and performances obtained.

Elementary design changes are in line with the field of direct application of test results as given in the test standard for non-load bearing elements: BS EN 1364-1:2015.

This assessment is for national application only and does not constitute a direct or extended field of application report in terms of the relevant European standards. The report evaluates the potential fire resistance performance, if the elements were to be tested in accordance with BS EN 1634-1 and BS EN 1363-1:2012 and is only valid if presented in its entirety.

Much of the guidance that supports fire safety legislation in the UK is given in terms of performance in relation to British or European Standards which may take the form of test methods or agreed product standards.

Typically therefore a material, product or structure should:

- a) have a specification or design which has been shown by test to be capable of meeting the required performance; or
- b) have been assessed from test evidence generated against appropriate standards, or by using relevant design guides, to be capable of meeting the required performance.

This approach is outlined as being acceptable in paragraphs 1 a) and b) of appendix A in Approved Document B Vol. 1 - Dwellinghouses (2006 edition incorporating 2010 and 2013 amendments) and Approved Document B Vol. 2 - Buildings other than dwellinghouses (2006 edition incorporating 2007, 2010 and 2013 amendments), the Passive Fire Protection Federation (PFPF) guidelines to undertaking assessments in lieu of fire tests and EGOLF Agreement EGA 10 Rev 2: 2014.

Test reports provide information on the performance of a specimen that was tested against the relevant standard and do not offer any extension to scope (e.g. leaf dimensions or hardware options). Assessments are written based on applicable primary test evidence and extend the scope of application of the tested design to provide for different design options and are written by person(s) with the necessary expertise in the performance of construction products under fire test conditions, as detailed in appendix A of Approved Document B Vol. 1 and Vol. 2.

This assessment has been written to the principles outlined in the PFPF guidelines to undertaking assessments in lieu of fire tests. The aim of the PFPF guidelines is to give confidence to end-users that assessments that exist in the UK are of a satisfactory standard to be used in lieu of fire tests for building control and other purposes.

The PFPF guidelines are produced by the UK Fire Test Study Group (FTSG) an association of the major fire testing laboratories in the UK and are published by the PFPF, the representative body for the passive fire protection industry in the UK.

2 Description of Vistamatic VS2

2.1 General

The Vistamatic VS2 vision panel comprises a double glazed unit with an additional, movable, centre layer of obscure glass.

The drawing below shows the essential elements of the double glazed unit. The 10mm thick toughened glass must be oriented to the fire risk side of the doorset.

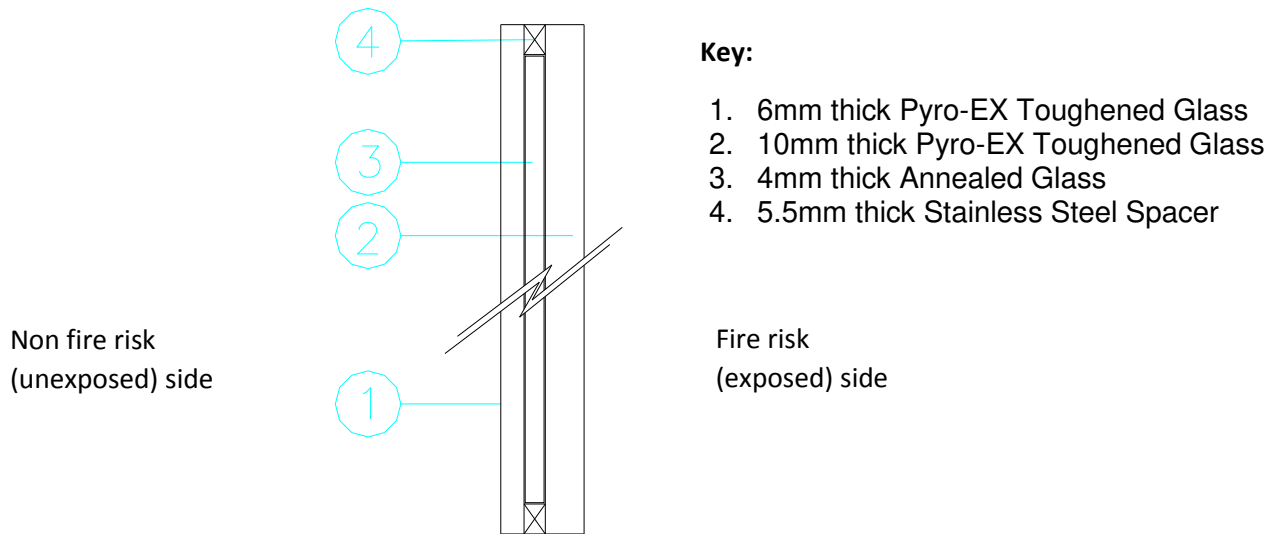

The vision panel is retained within the door leaf or screen element with either timber or steel beads, which must meet the specifications below.

2.2 Timber Beads

Element	Specification
Timber Bead material ² :	Hardwood (min density 640kg/m ³)
Glazing System ⁴ :	10mm high x 3mm thick Pyroglaze30 – Mann McGowan Ltd
Aperture liner ¹ :	3mm thick Intumescent Mastic – Norsound Ltd
Bead fixings ³ :	40mm long no. 6-8 steel screws or 40mm long x 1.8mm diameter steel pins located at minimum 150mm centres and 50mm from each corner. Fixings must be inserted at 35-40° to the vertical and located to 'cradle' the vision panel.
Minimum required bead size:	20mm (h) x 17mm (w) including a 9mm x 9mm bolection return. Bead to be chamfered 10-15°.
Additional information:	See section 6

The superscript numbers in the table above refer to the numbered elements in the drawing below:

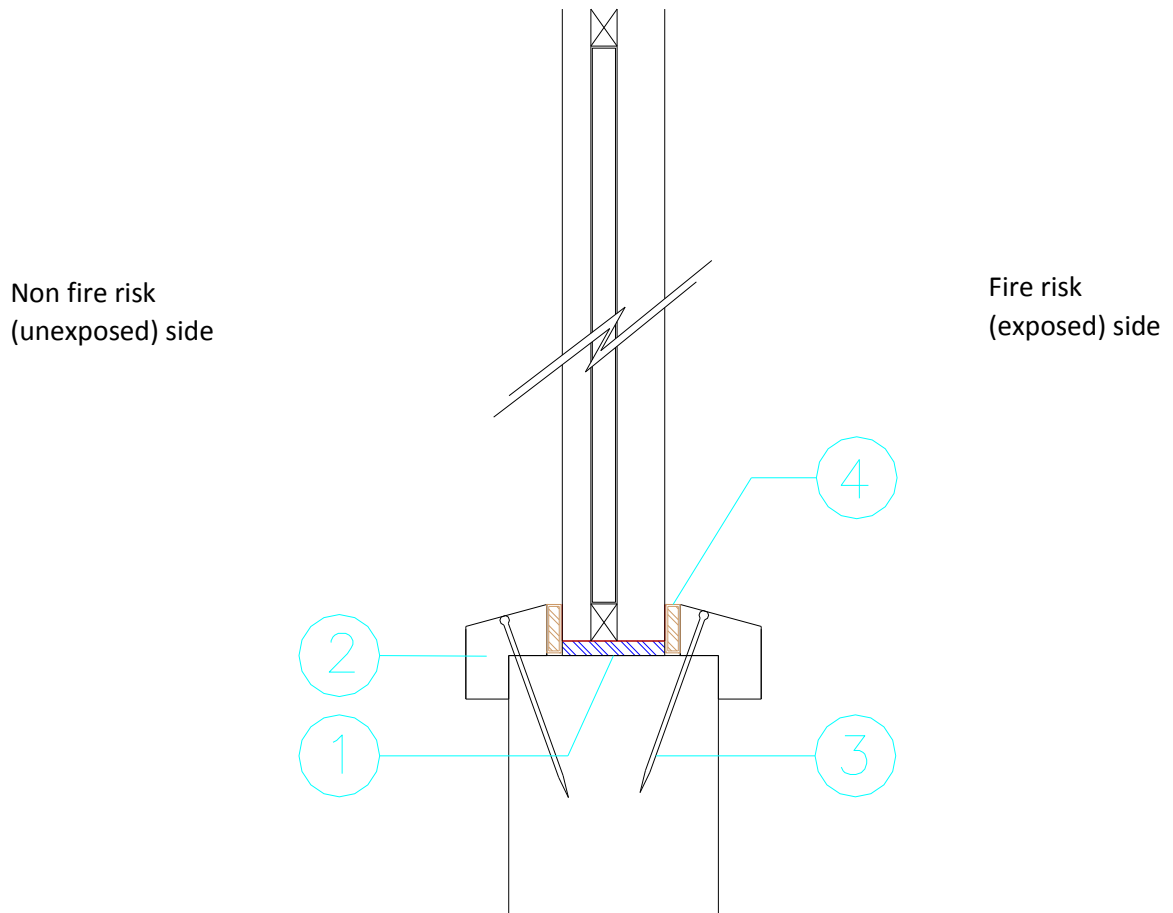

2.3 Steel Beads

Element		Specification
Bead material:		2mm thick stainless steel
Glazing System ³		10mm high x 2.5mm thick Raw Graphite ref: 2.5-390 x 10/SA – Norsound Ltd
Aperture liner ⁵ :		Intumescent Liner ref: 1.8-408 x 53/SA – Norseal Ltd
Bead fixings ¹ :		40mm long M5 machine steel screws fixed from the exposed face to threaded studs welded to the unexposed face beads located at minimum 170mm centres and 20mm from each corner.
Bead Profile	Exposed Face ⁴	50mm high x 2mm thick
	Unexposed Face ²	50mm high x 20 mm deep x 2mm thick
Additional information:		See section 6

The superscript numbers in the table above refer to the numbered elements in the drawing below:

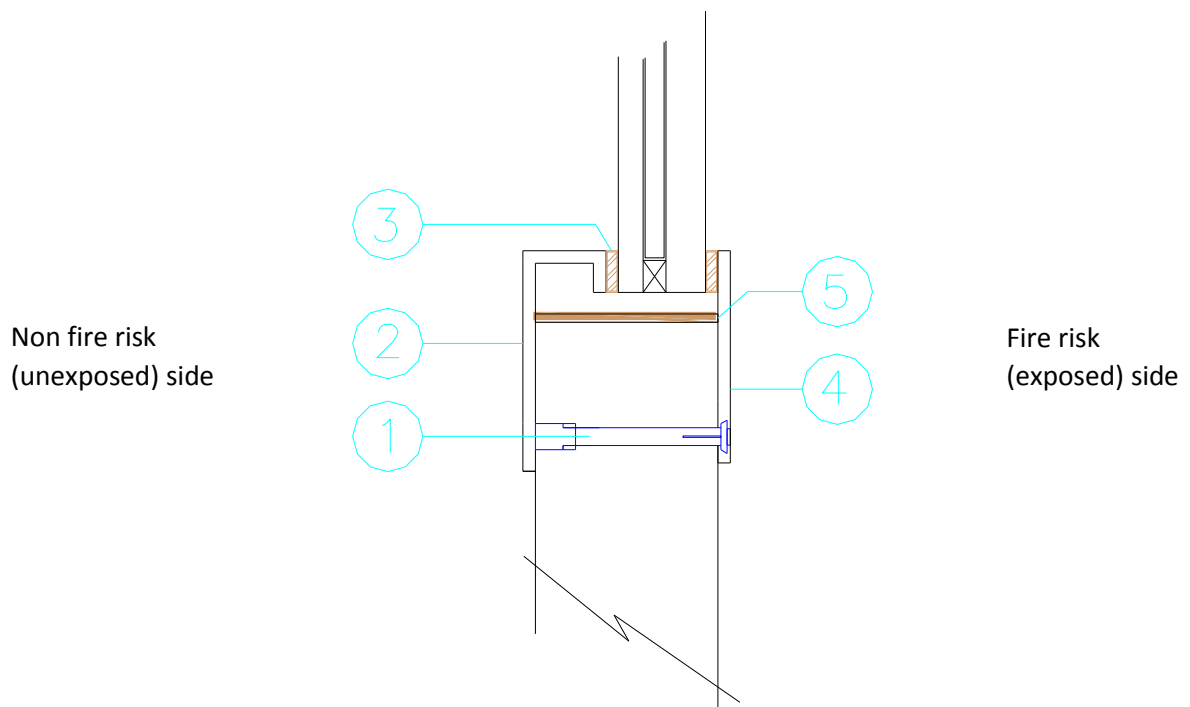

3 Scope of Application for Vistamatic VS2

3.1 Proprietary fire resisting doors

It has been proposed to summarise the use of the Vistamatic VS2 with the following proprietary fire resisting doorset designs.

This report will only consider the aperture size relevant to each doorset design for use with the Vistamatic VS2. For all other details, the full construction requirements in the assessment documentation relevant to the chosen doorset must be referred to.

Manufacturer	Product	Integrity Rating	General Description
Falcon Panel Products	Strebord 44	30	Graduated density particle board
Halspan	30 Prima	30	Tri layer particle board
Pacific Rim Wood	Flamebreak 30	30	Lamel 3-layer core door with various facing coverings
Blankfort Inc	Blankfort 30 & 30+	30	Lamella core door with various facing coverings
Egger (UK) Ltd	Eurospan	30	Graduated density chipboard

All of the above designs have been tested and proven to BS 476: Part 22: 1987 and/or BS EN 1634-1: 2000 or 2008. The global assessment documentation relevant to each door type is referenced before the data sheet for each proprietary door type - contained in section 4 below.

3.2 Non-proprietary timber based fire resisting doors

The Vistamatic V2 vision panel has been successfully subjected to testing for 30 minutes fire resistance to BS EN 1634-1: 2008 and BS EN 1363-1: 1999 and is therefore approved for use with different types of timber door construction, subject to the provisos contained in this report. In addition to the assessed proprietary door designs above, the Vistamatic VS2 is assessed for use with the following timber based generic types of fire resisting doorsets:

- Graduated density chipboard and three layered particleboard door blanks.
- Softwood or hardwood laminated door constructions with tested or assessed cellulosic facings.
- Stile and rail constructions with flax, chipboard or timber based cores.
- Stile and rail constructions with non-combustible sub-facings.

Assessment of these generic design types is subject to the following four provisos:

1. This report will only consider the aperture size relevant to each doorset design for the Vistamatic VS2.

2. The maximum glazed area assessed for Vistamatic VS2 installations within timber based door designs not specifically mentioned in the data sheets in section 4 is 1.0m².
3. The door blank must have been previously tested for fire resisting performance with installed glazing at a UKAS accredited laboratory or assessed for use with glazing by Exova Warringtonfire. The glazed area stated herein is the maximum that may be installed within any selected blank. If the permitted area within the selected blank's supporting documentation is smaller, that area must take precedence.
4. For all other details, the full construction requirements in the relevant door blank manufacturer's test evidence or assessment documentation must be complied with, including the margins specified within the relevant test or global assessment between glazed apertures and the leaf edges and between multiple glazed apertures.

3.3 Assessed Glass

Glass used for the, non fire risk (unexposed) panes of the Vistamatic VS2 vision panel must either be as tested (see section 2) or the assessed variations shown in the table below.

Glass Thickness Combination (mm)	Permitted Bead Type	
	Timber (section 2.2)	Steel (section 2.3)
6 thick - non fire risk side with 10 thick - fire risk side	√	√
10 thick - non fire risk side with 10 thick - fire risk side	√	√

Notes:

1. Glass combination as tested with the 10mm glass oriented to the exposed face.
2. 6mm glass elements must NOT be oriented to the fire risk side.
3. Where 6mm glass is used, the vision panel will be uni-directional with respect to fire risk; care must be taken to ensure the unit is installed the correct way round otherwise the fire resistance performance will be compromised.
4. When specifying panels, the required orientation of the operating handle for the central pane must be considered in relation to the fire risk side.
5. The bead profile shown as item 2 in section 2.3 may be adjusted in depth only, in order maintain the flush fit of the beads - to suit the specified glazing thickness.
6. Glass must be Pyro-EX Toughened Glass.
7. Other than the glass thickness, as shown in the table above, all installation provisions must remain as shown in section 2. In particular, the edge cover of the toughened fire rated glass must remain as tested.

4 Data Sheets

The maximum glazed area shown may be comprised of multiple openings, subject to the minimum framing dimensions stipulated within the appropriate supporting global assessment.

The global assessment report references given below are current at the time of issue of this report. It is the responsibility of the users of this report to contact the manufacturer of the specified doorset to ensure the most up to date revision of each global assessment is used. Subsequent revisions to the reports below will supersede them and the provisions within may change and must be complied with.

4.1 Falcon Panel Products – Strebord 44

Door manufacturer:		Falcon Panel Products Ltd
Door core reference:		Strebord 44
Global assessment report reference:		Chilt/A02066 Revision L
Description:		Graduated density chipboard blank
Maximum permitted glazed area (m²)	Single Aperture	1.0
	Multiple Apertures	1.9

4.2 Halspan Ltd – Prima 30

Door manufacturer:		Halspan Ltd
Door core reference:		30 Prima
Global assessment report reference:		FEA/F97174 Revision I
Description:		Tri-layer particle board
Maximum permitted glazed area (m²)	Single Aperture	1.0
	Multiple Apertures	1.25

4.3 Pacific Rim Wood Ltd – Flamebreak 30

Door manufacturer:		Pacific Rim Wood Ltd
Door core reference:		Flamebreak 30
Global assessment report reference:		FEA/F98164 Revision M
Description:		Lamella core door with various facing coverings
Maximum permitted glazed area (m²) Single or multiple apertures		1.15

4.4 Blankfort Inc – Blankfort 30

Door manufacturer:		Blankfort Inc
Door core reference:		Blankfort 30 & 30+
Global assessment report reference:		Chilt/A12151 Revision D
Description:		Lamella core door with various facing coverings
Maximum permitted glazed area (m²)	Single Aperture	1.0
	Multiple Apertures	1.32

4.5 Egger (UK) Ltd – Eurospan 30

Door manufacturer:		Egger (UK) Ltd
Door core reference:		Décor 44
Global assessment report reference:		Chilt/A13085 Revision D
Description:		Graduated density chipboard blank
Maximum permitted glazed area (m²)	Single Aperture	1.0
	Multiple Apertures	1.29

5 Side Panels and Fanlights

The Vistamatic VS2 may be used to glaze fanlights and/or side panels.

The maximum assessed fanlight height is 600mm.

The maximum assessed side panel width is 500mm.

The maximum glazed area for a single panel (fanlight or side panel) is 1.0m².

If the required glazed area of the fanlight or side panel exceeds the area stated above, timber framing elements must be installed (jointed as in section 5.1 below) to divide up the glazing area to meet the maximum single panel area of 1.0m².

Notes:

1. Side panels are only permitted with an assessment or test evidence, proving their performance with the doorset in question and at the size required.
2. The door frame, fanlight, and side panel framing, must all be hardwood with a minimum density of 640 kg/m³.
3. The frame section must be a minimum of 70mm x 44mm.
4. All other installation details of the Vistamatic VS2 must otherwise meet the provisions within section 2.

5. Frame joints may be mortice and tenoned, mitred, half lapped or butted (see diagrams below). Joints for transoms must be mortice and tenon. Joints must be tight with no gaps and all jointing methods must be mechanically fixed with the appropriate size ring shank nails or screws.

The following diagrams illustrate the approved joint types

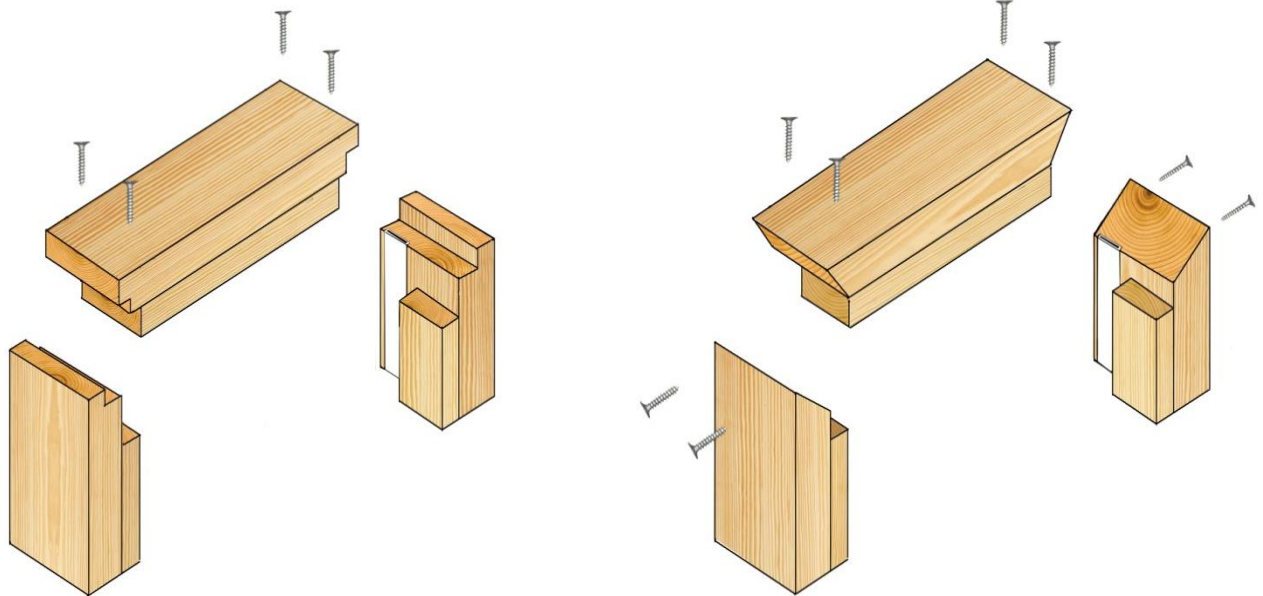

Half Lapped Joint

Mitre Joint

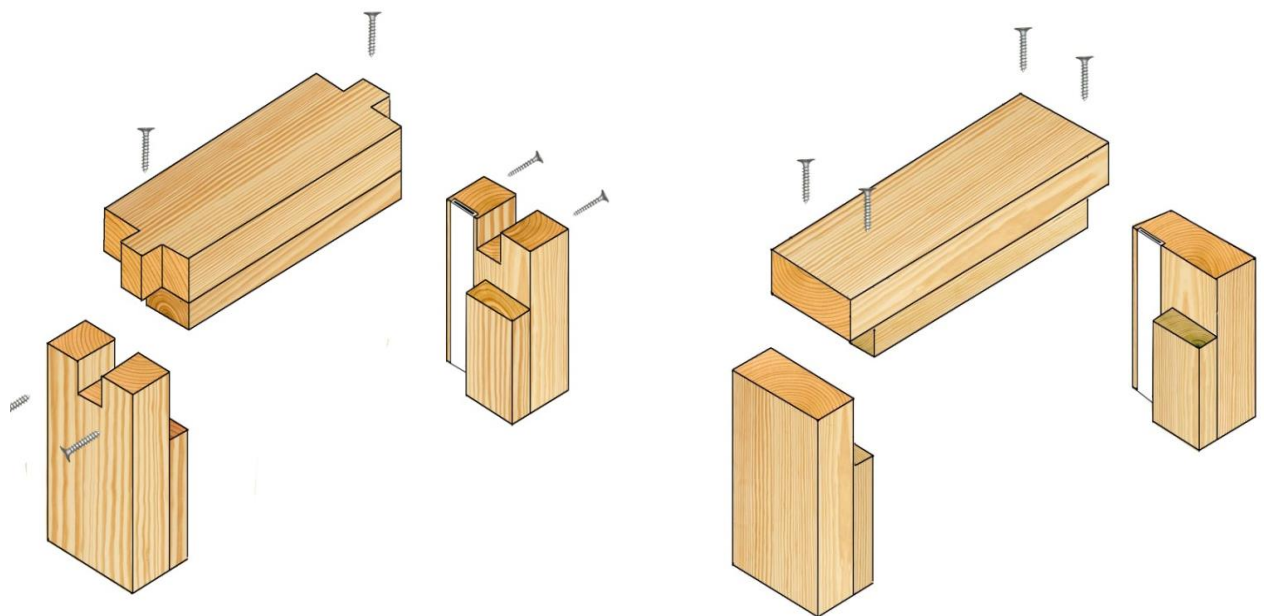

Mortise and Tenon Joint

Butt Joint

Diagrams are representative. Actual construction and intumescent must be either as specified in this document, a tested construction, or the referenced global assessments.

6 Additional Installation Requirements

In addition to the provisos above, the following points must be considered when glazing fire resisting doorsets using the Vistamatic VS2 vision panel.

1. Gaps between glass and framing, to permit expansion, should be set at 2 - 3mm on all edges, using non-combustible or hardwood setting blocks at the bottom edge.
2. If it is necessary to increase the height of the timber bead beyond the minimum stated in section 2.2, the length of the bead fixing must be increased commensurately, to ensure that the fixings locate into the door core to a depth of approximately 20 - 25mm.
3. Glazing beads must be retained in position with minimum 50mm long x 2mm diameter steel pins or 50mm long No 6 - 8 screws, inserted at 35 - 40° to the vertical. Fixings must be at 150mm maximum centres and with a fixing at no more than 50mm from each corner
4. Timber for glazing beads must be straight grained joinery quality hardwood, free from knots, splits and checks.

Alternatively, pneumatically (gun) fired steel pins are acceptable providing the pins meet the specifications shown below, are a minimum of 60mm long, and for rectangular or oval pins are orientated perpendicularly to the glass where possible.

Round pin diameter (mm) = minimum 1.6mm:

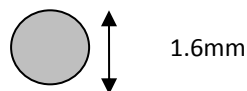

Oval/rectangular pin minimum linear dimensions = 1.6mm x 1.4mm:

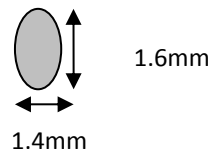
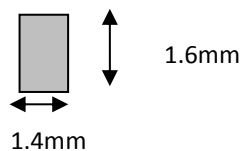

7 Conclusion

If Vistamatic VS2 vision panels were to be used for glazing fire resisting doors, sidescreens, or fanlights, in accordance with the specification documented in this report, and were to be tested in the appropriate configuration in accordance with BS EN 1634-1:2014+A1:2018 and BS EN 1363-1: 2012, it is the opinion of Exova Warringtonfire that the glazing installation would achieve a minimum of 30 minutes integrity.

8 Declaration by the Applicant

- 1) We the undersigned confirm that we have read and comply with obligations placed on us by FTSG Resolution No 82: 2001.
- 2) We confirm that the component or element of structure, which is the subject of this assessment, has not to our knowledge been subjected to a fire test to the Standard against which this assessment is being made.
- 3) We agree to withdraw this assessment from circulation should the component or element of structure be the subject of a fire test to the Standard against which this assessment is being made.
- 4) We are not aware of any information that could adversely affect the conclusions of this assessment.
- 5) If we subsequently become aware of any such information we agree to ask the assessing authority to withdraw the assessment.

Signed:

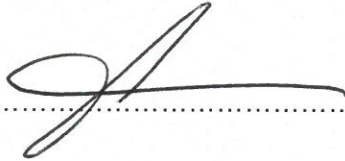

Name: MARK NASH

For and on behalf of Vistamatic Ltd.





9 Limitations

The following limitations apply to this assessment:

- 1) This assessment addresses itself solely to the elements and subjects discussed and does not cover any other criteria. All other details not specifically referred to should remain as tested or assessed.
- 2) This assessment is issued on the basis of test data and information to hand at the time of issue. If contradictory evidence becomes available, Exova Warringtonfire reserves the right to withdraw the assessment unconditionally but not retrospectively.
- 3) This assessment has been carried out in accordance with Fire Test Study Group Resolution No 82: 2001.
- 4) Opinions and interpretations expressed herein are outside the scope of UKAS accreditation.
- 5) This assessment relates only to those aspects of design, materials and construction that influence the performance of the element(s) under fire resistance test conditions. It does not purport to be a complete specification ensuring fitness for purpose and long-term serviceability. It is the responsibility of the client to ensure that the element conforms to recognised good practice in all other respects and that, with the incorporation of the guidance given in this assessment, the element is suitable for its intended purpose.
- 6) This assessment represents our opinion as to the performance likely to be demonstrated on a test in accordance with BS EN 1634:2014+A1:2018, on the basis of the evidence referred to herein. We express no opinion as to whether that evidence, and/or this assessment, would be regarded by any Building Control authority as sufficient for that or any other purpose. This assessment is provided to the client for its own purposes and we cannot opine on whether it will be accepted by Building Control authorities or any other third parties for any purpose.

10 Validity

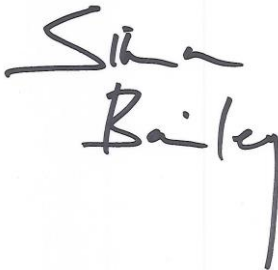
- 1) The assessment is initially valid for five years after which time it must be submitted to Exova Warringtonfire for technical review and revalidation.
- 2) This assessment report is not valid unless it incorporates the declaration given in Section 8 duly signed by the applicant.

Signature:		
Name:	Simon Bailey	Dr K D S Towler
Title:	Senior Product Assessor	Senior Product Assessor

Appendix A

Performance Data

Vistamatic glazing evidence

Report No	Configuration	Leaf Size (mm)	Test Standard	Performance (mins)
RF12065 (Particleboard Blanks)	2No LSASD A – timber beads B – Steel Beads	A & B 2100 1140 44	BS EN 1634-1: 2008 and BS EN 1363-1: 1999	A - Integrity: 30 B - Integrity: 34
IF12021	Hinged Door Leaf Section	1005 928 44	BS EN 1634-1: 2008	Integrity: 44

Assessed Proprietary Doorsets

Report No	Configuration	Leaf Size (mm)	Test Standard	Performance (mins)
Chilt/A02066 Revision L Strebord 44 Falcon Panel Products	Various	Various	BS 476: Part 22: 1987	30
FEA/F97174 Revision I Halspan® 30 Prima Halspan Ltd	Various	Various	BS 476: Part 22: 1987	30
FEA/F98164 Revision M Flamebreak 30 Pacific Rim Wood Ltd	Various	Various	BS 476: Part 22: 1987	30
Chilt/A12151 Revision D Blankfort 30 & 30+ Blankfort Inc.	Various	Various	BS 476: Part 22: 1987	30
Chilt/A13085 Revision D Decor 44 Egger (UK) Ltd	Various	Various	BS 476: Part 22: 1987	30

